

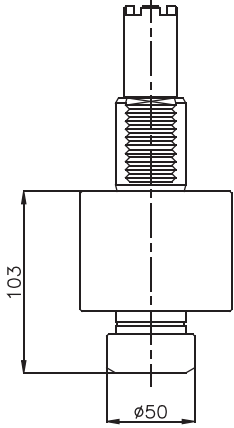

HAAS

SL-20
SL-30

P.000 AXIAL
P.005 AXIAL INTERNAL COOLANT



P.021 RADIAL ADJUSTABLE

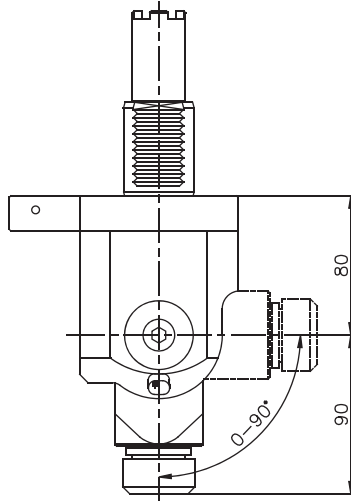

P.030 SAW-MILL

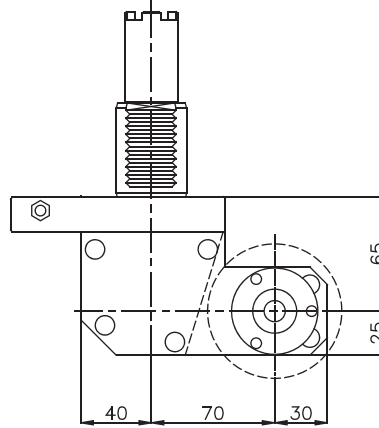

P.010 RADIAL
P.016 RADIAL INTERNAL COOLANT

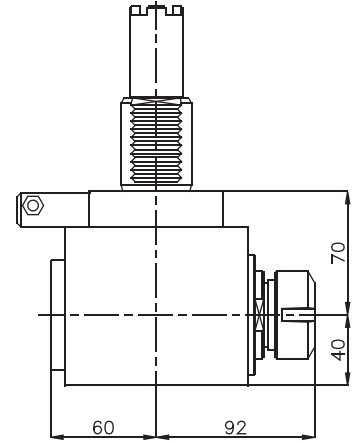

P.011 RADIAL SET-BACK
P.017 RADIAL SET-BACK INTERNAL COOLANT

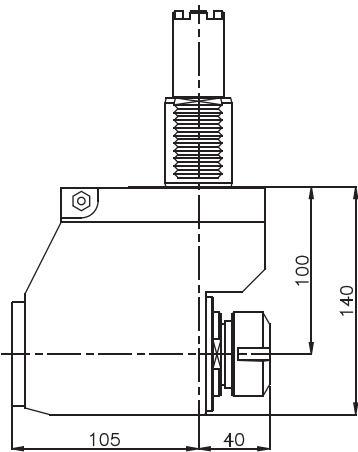

P.033 RADIAL SUBSPINDLE

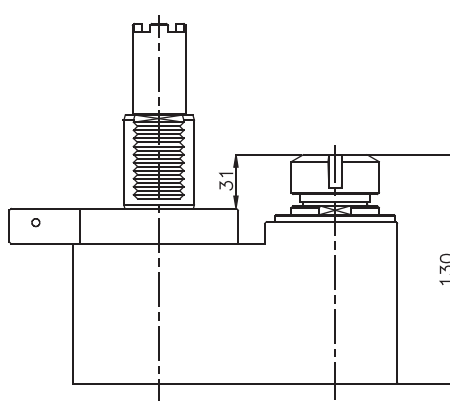

P.008 RADIAL DOUBLE OUTPUT

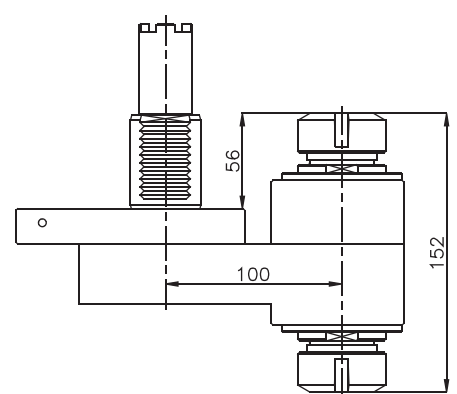

Order Code	MODEL	Tool Style	Spindle	MAX RPM	GearRatio	Nm
HS.000.SL20	SL-20, SL-30	AXIAL	ER-32	5000	1:1 >	55
HS.021.SL20	SL-20, SL-30	ADJ ANGLE	ER-25	5000	1:1 <	14
HS.030.SL20	SL-20, SL-30	SAW-MILL	Upon request	3000	1:1 <	55
HS.010.SL20	SL-20, SL-30	RADIAL	ER-32	5000	1:1 <	55
HS.011.SL20	SL-20, SL-30	RADIAL SET-BACK	ER-32	5000	1:1 <	55
HS.033.SL20	SL-20, SL-30	RADIAL SUBSPINDLE	ER-32	5000	1:1 >	55
HS.008.SL20	SL-20, SL-30	FACE/SUB-SPINDLE	ER-32/ER-32	5000	1:1 <<	55

OTHER MODELS PLEASE ASK © MADAULA SA. SUBJECT TO CHANGE WITHOUT NOTICE

FOR MORE INFORMATION ASK FOR SPECIFIC LITERATURE



OPTION CODE

- CW INPUT = CW OUTPUT
- CW INPUT = CCW OUTPUT

ALSO AVAILABLE:

- SPEED INCREASING
- SPEED REDUCTION
- RADIAL TOOL REVERSES FOR SUB-SPINDLE

