

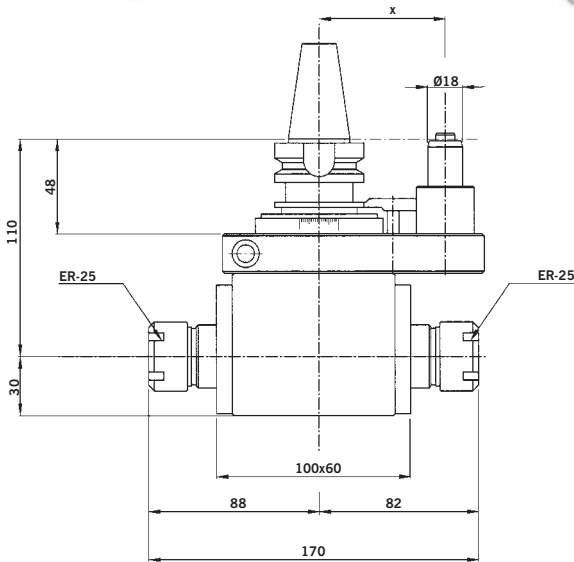

- ▶ High precision preloaded bearings
- ▶ **Roulements de haute précision préchargés**
- ▶ *Hochpräzise, vorbelastete Wälzlager*
- ▶ **Rodamientos de precisión precargados**
  
- ▶ Wide production range
- ▶ **Programme de production complet**
- ▶ *Ein vollständiges Fertigungsprogramm*
- ▶ **Completo programa de producción**

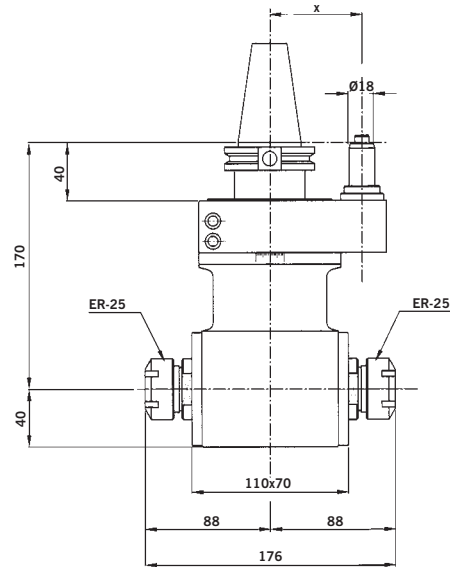

- ← **CAD-0**
- ▶ *Less tool changes*
  - ▶ *Moins de changements d'outil*
  - ▶ *Wenige Werkzeugwechsel*
  - ▶ *Menos cambios de herramienta*



- ← **CAD-1**
- ▶ *Less room occupied in tool changer*
  - ▶ *Moins d'espace occupé dans le magasin*
  - ▶ *Wenig besetzter Platz im Lager*
  - ▶ *Menos espacio ocupado en almacén*

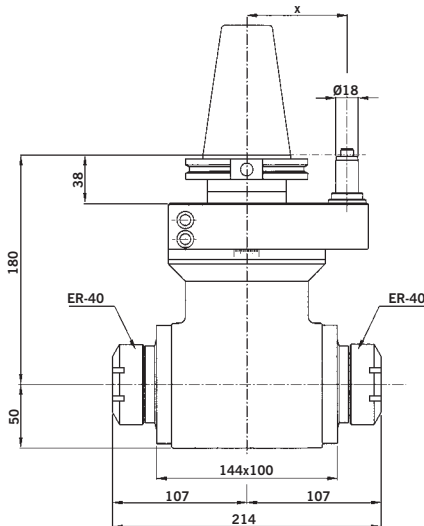

- ← **CAD-2**
- ▶ *Two heads in one*
  - ▶ *Deux renvois en un*
  - ▶ *Zwei Köpfe in einem*
  - ▶ *Dos cabezales en uno*

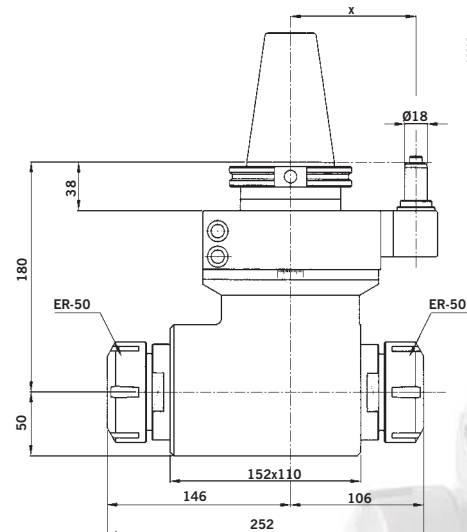

- ← **CAD-3**
- ▶ *Less costly machining process*
  - ▶ *Moindre coût d'usinage*
  - ▶ *Kostengünstiges Bearbeitungssystem*
  - ▶ *Menos costes de mecanizado*

FEATURES / CARACTÉRISTIQUES / MERKMALE / CARACTERÍSTICAS

	CAD-0	CAD-1	CAD-2	CAD-3
R.P.M. max	5.000	3.000	2.500	2.000
KW	3,5	5	14	20
Ø MAX	16	16	26	34
KG	5Kg	8Kg	15Kg	25Kg
↔	1:1	1:1	1:1	1:1
Nm. max	16	22	65	90
ISO/DIN/MAS BT	30/40	40/50	50	50
HSK	50/63	63/100	80/100	80/100

(\*) According to the machine / Suivant la machine / Nach der Maschine / Según máquina